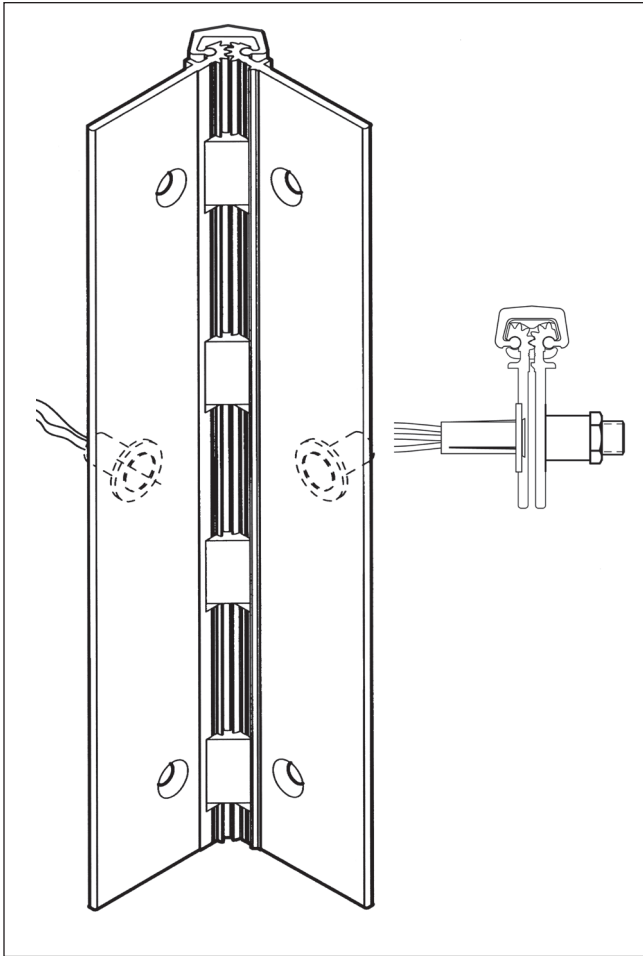

CMG (Concealed Adjustable Monitor Switch)

PREP: SELECT geared continuous hinges can be prepared for a concealed adjustable magnetic monitor switch to provide non-continuous current. 22 gauge wire with 14" leads. 28V DC.

LOCATION: Specify the dimension from the top of the hinge to the centerline of the CMG. Avoid putting the CMG within one inch of a fastener hole. Hinge is installed flush with the top of the door.

Refer to the templates in the Concealed Geared Hinge section to choose appropriate CMG location. These templates are also available online at www.SelectHinges.com.

HANDING: Specify the handing of each door requiring the CMG.

ORDER: Use suffix "CMG," plus the location and handing. Only one CMG is required per monitoring hinge.

Example: SL24 HD 83" Clear CMG 36" from top of hinge to centerline, RH.

AVAILABILITY: Available on geared hinge models SL11, SL12, SL14, SL18, SL24, SL26, SL27, SL31, SL40, SL41, SL44, SL48 and SL84.

LEAD TIME: 48 hours (on most orders).

WARRANTY: 5 years on electrical modification components.

IMPORTANT: SELECT Products Limited does not recommend preparing door and frame for CMG before receipt of hinge. If door and frame must be prepared before receipt of hinge, contact factory for special template.