

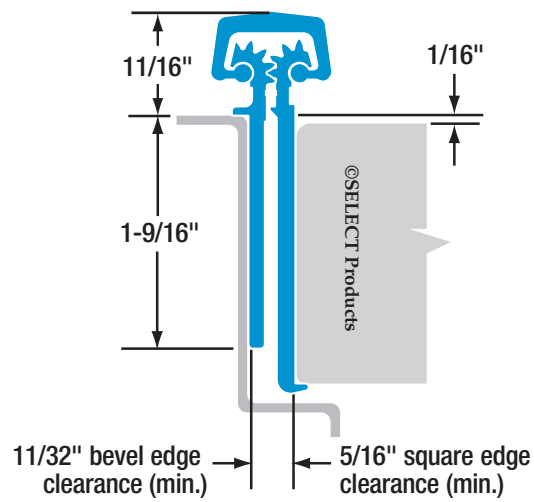

- 1/6" door inset
- For 1-3/4" doors
- Narrow frame leaf
- Door edge protector

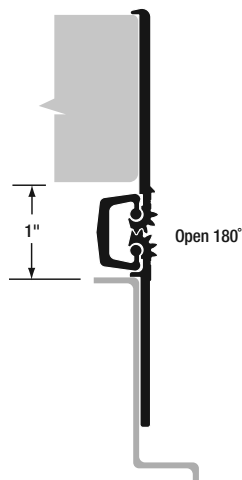

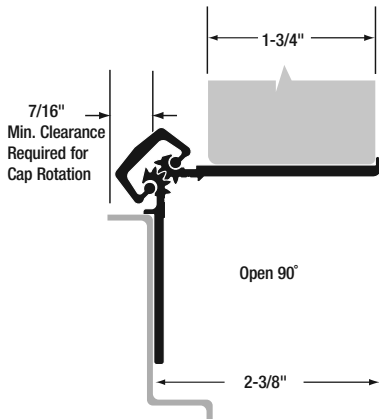
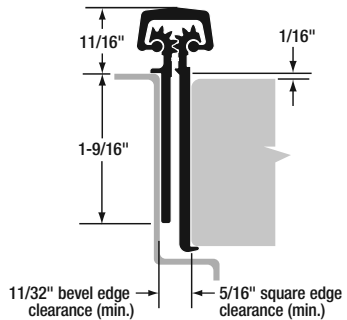

MATERIAL: Extruded 6063 T6 aluminum alloy with self-lubricating polyester thrust bearings.

LENGTHS: 83", 85", 95" and 120" lengths standard for nominal door heights. Custom lengths are available.

RATINGS: Standard Duty — Tested per BHMA standards for medium frequency applications. For doors 48" wide (max.) in 16 gauge hollow metal (min.) or 1/8" aluminum (min.) weighing up to 200 pounds without frame or door reinforcement.

Heavy Duty — Tested per BHMA standards for high-frequency or heavy, medium-frequency applications. For doors 48" wide (max.) in 16 gauge hollow metal (min.) or 1/8" aluminum (min.) weighing up to 450 pounds without frame or door reinforcement; up to 600 pounds with the use of Rivnuts in the frame and door.

FINISHES: All SL14 hinges are stocked in 204R1 Clear (.4–.7 mil) AA-M12C22A31 and 215 R1 Dark Bronze (.7 mil and thicker) AA-M12C22A44 anodized aluminum. Custom anodized or painted finishes are available. Product painted or anodized in the field voids the SELECT hinge warranty.

CLOSERS: Conventional overhead surface, concealed sliding arm overhead or floor closers may be used with SELECT hinges. Pivot-type floor closers (with a fixed, conflicting center pivot) must be replaced.

ORDER: Specify length, finish and standard-duty (SD), heavy-duty (HD). Also, specify door and frame screw applications. 12-24 x 1/2" thread-forming 410SS Phillips undercut flathead screws are provided as a standard pack unless otherwise specified. Wood and self-drilling, thread-forming screws also available. Security screws optional at extra cost.

BHMA CERTIFICATION: SL14HD geared continuous hinges conform to BHMA Standard ANSI/BHMA A156.26.2006 Grade 2.

SL14 HINGE SCREW COUNT		
HINGE LENGTH & DUTY RATING	DOOR SCREWS	FRAME SCREWS
83" SD/HD	19	19
85" SD/HD	19	19
95" SD/HD	21	21
120" HD	23	23

SPECIFICATIONS

SL14 Concealed Geared Hinge



SELECT Advantages



PAIR-MATCHED™ HINGE LEAVES

Manufactured together, machined together and anodized together, making SELECT hinges fit your doors better and last longer. *An exclusive SELECT benefit.*

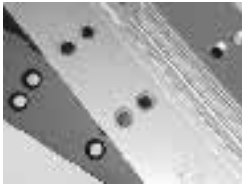

ANODIZED AFTER MACHINING

Hard, smooth surface delivers superior wear, durability and life, inhibits corrosion. Not all hinge makers follow SELECT's lead in using this superior manufacturing process.



LIFETIME LUBRICATION

Eliminates the need for periodic maintenance. Quiet performance. Fights gear cap wear. *An exclusive SELECT benefit.*



CONSISTENT TEMPLATING

Hole pattern is identical on both Standard and Heavy Duty models—a SELECT benefit not all hinge makers offer.



PATENTED 3-HR. FIRE RATING

Available without pins or studs. No extra parts to buy or install, no liability worries. Design innovation approved for positive and negative pressure. *An exclusive SELECT benefit.*



TEMPLATED HOLE PATTERN

Select hinges line up perfectly, precisely, every time. Makes multiple installations easier and faster. *An exclusive SELECT benefit.*



COATED FASTENERS

Provide additional corrosion protection with either self-drilling thread-forming (SDTF) or thread-forming (TF) screws. *An exclusive SELECT benefit.*



CUSTOM COLORS

Match any anodized or paint color on the gear cap or the entire hinge and fasteners, including our always in-stock Bone White gear caps.

SELECT Hinge Performance

- A SELECT geared continuous hinge has been tested in accordance with ANSI 250.4-1994 test procedure and acceptance criteria for physical endurance for steel doors and hardware and has surpassed 25,000,000 cycles during testing by an independent laboratory. On a door cycling 400,000 times per year, a SELECT hinge will be performing for over 62 years.
- SELECT geared continuous hinges are built to handle abuse from high-traffic applications. They are applied to the surface on the edge of the frame and door. No machining or reinforcement is required.
- The revolutionary SELECT geared continuous hinge puts an end to costly and irritating hinge failure problems, the most common cause of entrance failure.
- On conventional hinges, opening and "kick-back" energy concentrate on a few inches of fastened reinforcing plate — with the top hinge handling 100% of the force. Pinless SELECT hinges bond the door and frame into an integrated, sag-free unit. "Kick-back" energy dissipates along the entire length of the door and frame. (Compare this to a conventional hinge's 4-1/2" to 5" at the top of the door and frame).
- SELECT geared continuous hinges eliminate the gap between the door and frame, providing a weatherproof, rust-proof, tamper-proof barrier. When the door is closed, there are no accessible screws, bolts or pins.
- SELECT geared continuous hinges are tested and listed by Underwriters Laboratories Inc. to standards UL10B, UL10C (positive pressure) and UBC7.2. Hinges are fire-rated for up to 1-1/2 hours. A special patented process can be added to increase the fire rating to THREE hours (NO PINS REQUIRED). Contact SELECT for more information.

