

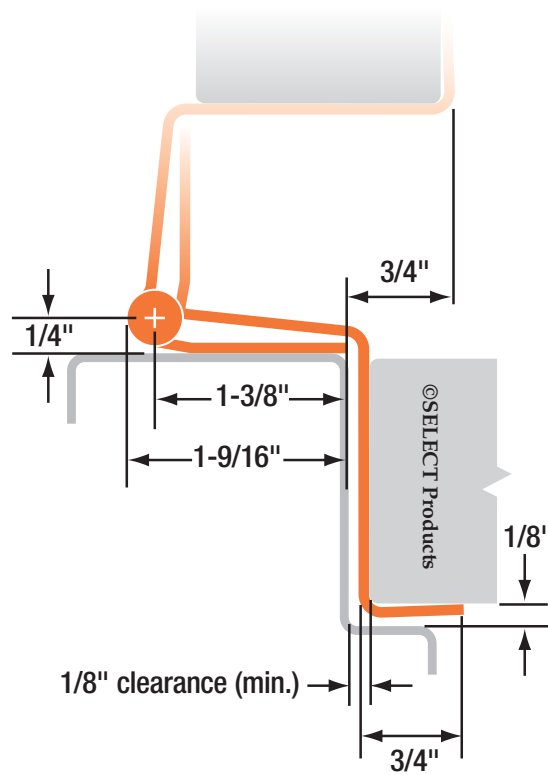

- Stainless steel
- For doors weighing up to 600 lbs.
- 48" max. door width

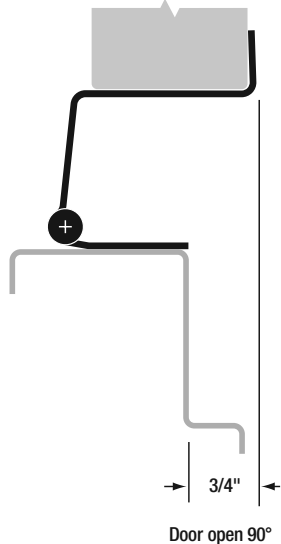

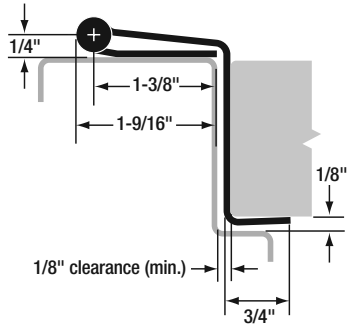

MATERIAL: 14 gauge 304 stainless steel with .25" diameter 304 stainless pin. Long-life nylon split bearings.

LENGTHS: 83", 85", 95" and 120" lengths standard for nominal door heights. Custom lengths are available.

RATINGS: For doors 48" wide (max.) weighing up to 600 pounds without frame or door reinforcement.

FINISH: US32D satin stainless steel (630).

CLOSERS: Conventional overhead surface, concealed sliding arm overhead or floor closers may be used with SELECT hinges. Pivot-type floor closers (with a fixed, conflicting center pivot) must be replaced.

ORDER: Specify hinge length. Universal screw pack contains 10-24 x 7/8" self-drilling 410SS Phillips undercut flathead screws and 10 x 1-1/4" Phillips undercut flathead sheet metal screws.

BHMA CERTIFICATION: SL311 pin & barrel continuous hinges conform to BHMA Standard ANSI/BHMA A156.26.2006 Grade 1.

SL311 HINGE SCREW COUNT		
HINGE LENGTH	DOOR SCREWS	FRAME SCREWS
83"	21	21
85"	18	18
95"	23	23
120"	27	27

SPECIFICATIONS

SL311 Swing Clear Pin & Barrel Hinge



SELECT Advantages



CORROSION-RESISTANT STAINLESS STEEL

Stainless steel pin & barrel construction creates a tough, highly secure opening.



TEMPLATED HOLE PATTERN

Select hinges line up perfectly, precisely, every time. Makes installation easier and faster.



NYLON DOUBLE BEARINGS

Create a strong, free-moving assembly that allows closers and other door hardware to function properly.



VARIETY OF FINISHES

Available in polished, brushed and painted finishes to match, contrast or accent your building's design.



3-HR. FIRE RATING

Fire-rated out of the package. No extra parts to buy or install, no liability worries.



1/4-IN. STAINLESS STEEL ROD

Delivers high tensile strength by forming a strong, free-moving unit. Flexible and strong in abused openings.



ADJUSTA-SCREW™ FASTENERS

Remedy out-of-square doors and frames easily. Correct fit variances up to 3/8" along full length of door.



END CAPS

Spiral-knurled steel caps seal the barrel ends to contain hinge rod.

- SELECT pin & barrel continuous hinges are tested and listed by Underwriters Laboratories Inc. to standards UL10B, UL10C (positive pressure) and UBC7.2.

