

# CTW (Concealed Through-Wire)

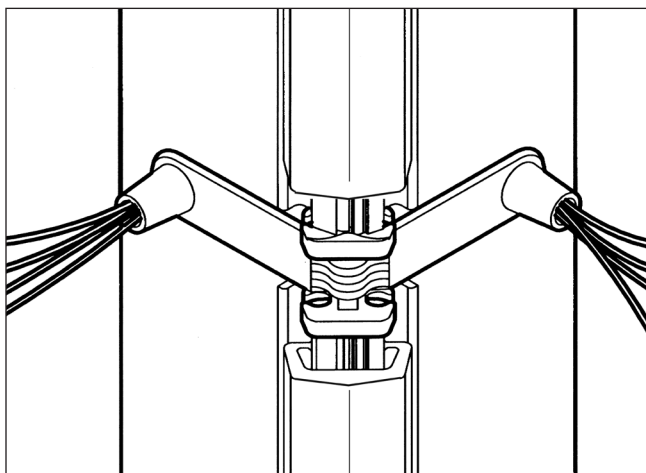
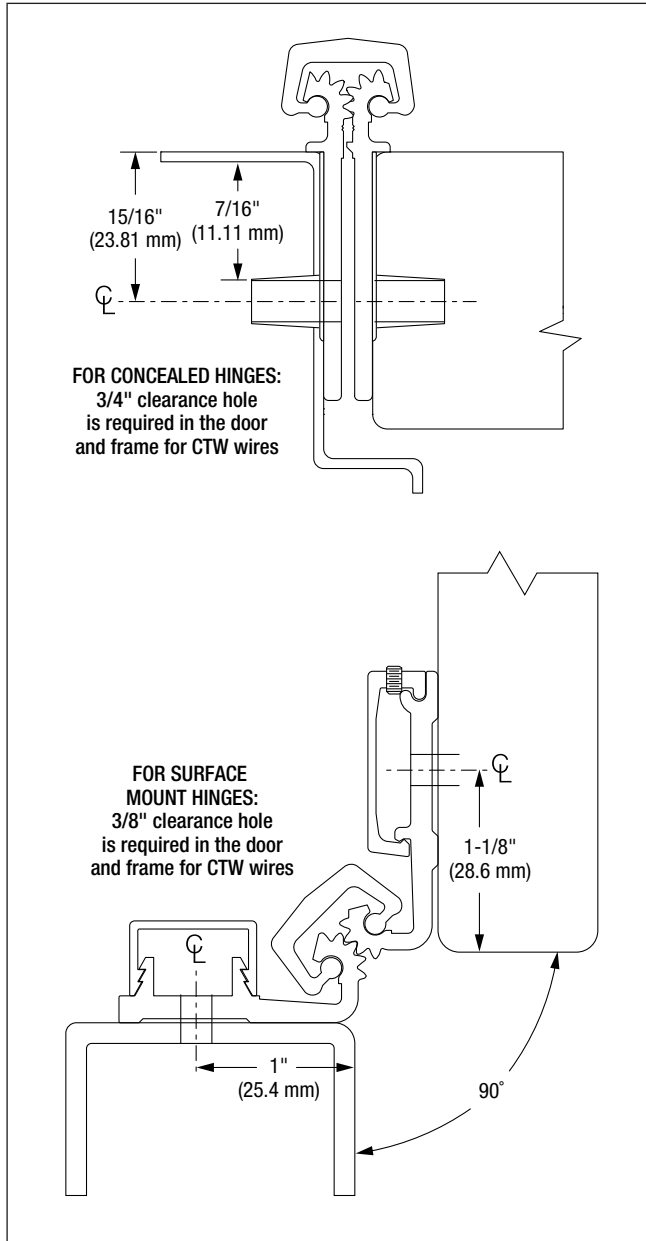

**PREP:** SELECT geared continuous hinges can be prepared for concealed electric through-wires to provide continuous current. Through-wires available in sets of 4, 5, 8, 10 or 12.

Per conductor: 12V-24V AC/DC at 3-6 amps. Ultra-flexible 22 gauge wire with 8" leads per leaf. Extra-long leads (48" max.) available.

**NOTE:** CTW4 and CTW5 preps require the replacement of one hinge bearing with a special bearing containing wires; CTW8 and CTW10 preps require the replacement of two bearings; CTW12 prep requires the replacement of three bearings.

**LOCATION:** Specify the dimension from the top of the hinge to each CTW bearing centerline. Hinge is installed flush with the top of the door.

*Refer to the templates in the Concealed or Full Surface Geared Hinge sections to choose from available CTW bearing locations. These templates are also available online at [www.SelectHinges.com](http://www.SelectHinges.com).*

**HANDING:** Specify the handing of each door requiring the CTW. Handing not required on SL11 and SL27.

**ORDER:** Use suffix "CTW," plus the number of wires required. Specify location of each CTW bearing and handing (if required).

*Example: SL24 HD600 83" Clear CTW4 42-25/32" from top of hinge to centerline, RH.*

**AVAILABILITY:** All CTW options available on heavy duty (HD600 and LL) models SL11, SL12, SL14, SL18, SL24, SL26, SL27, SL31, SL44, SL48 and SL84, and heavy duty (HD600) model SL57. Heavy duty (HD300) models SL11, SL14, SL18, SL24 and SL57 available with 4- or 5-wire CTW only.

**LEAD TIME:** 48 Hours (on most orders).

**WARRANTY:** 5 years on electrical modification components.

**IMPORTANT:** SELECT Products Limited does not recommend preparing door and frame for CTW before receipt of hinge. If door and frame must be prepared before receipt of hinge, contact factory for special template.

CTW PREP